

Technical
Information

HAI S - HXS and HTFS Open Loop ASIC based
Current Transducers from 5 to 800 A_{RMS} nominal
with reference access. Made to measure.

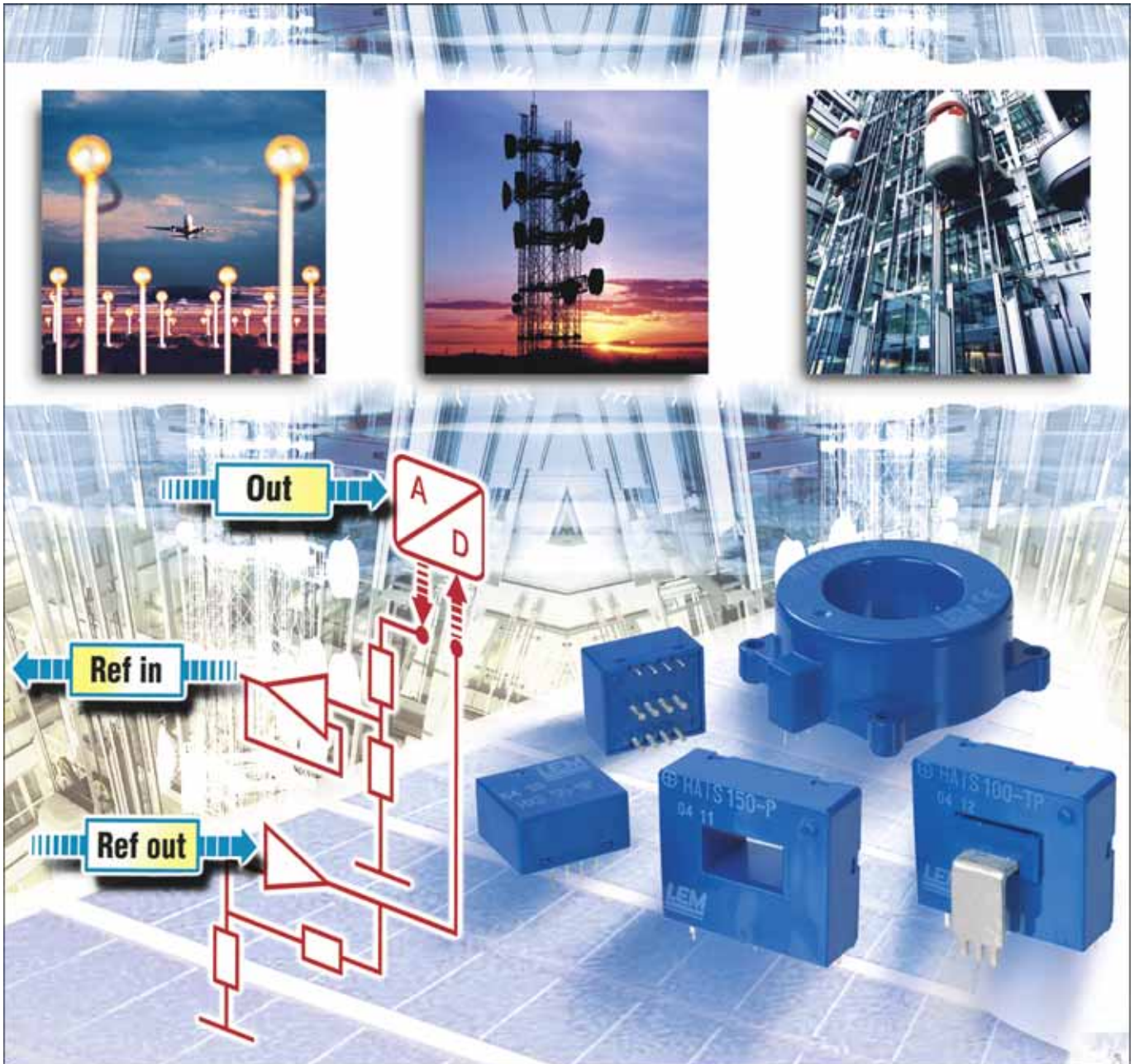

LEM

Low cost, High performance : You make the choice !

HAIS - HXS and HTFS Open Loop ASIC based Current Transducers from 5 to 800 A_{RMS} nominal with reference access. Made to measure.

by Stéphane Rollier, Marc Laforêt & Hans Dieter Huber

Today, the competitive environment has evolved into a global context. Power electronic requirements can be summarised as follows : Cost/no compromise on performances/small size/ + 5 volt power supply.

LEM, present in power electronic applications such as drives, Uninterruptible Power Supplies, Switched Mode Power Supplies, various Power Supplies... is the leader for current measurement bringing the control, monitoring and protection of

the equipment and doesn't miss the opportunity to answer to this new market requirement.

The solution : the use of an ASIC based Open Loop Hall effect current transducer.

The **ASIC** (Application Specific Integrated Circuit) as indicated by its name is an integrated circuit designed to provide several specific functions in one package. This opens new possibilities to answer to volume constraints or technical constraints such as low power supply use (single +5 Volt for example).

The single +5 Volt Power Supply is more and more common due to the presence of components like microprocessors, microcontrollers and A/D (Analog/Digital) converters in power electronics. All integrated circuits and associated components must match this power supply requirement.

This is also the opportunity to enter into new markets not accessible today, due to high cost or dimensions such as automotive applications. It was not LEM's first experience with ASICs. In 1997, LEM launched the new LTS transducer (fig. 1) as the first Closed Loop Hall Effect current transducer based on an **ASIC**.

This brought advantages never reached before, such as small

dimensions and a single +5 Volt power supply for a C/L transducer, as well as good accuracy thanks to an incorporated drift compensation system and an accurate internal voltage reference.

Since the LTS family became a best seller and LEM encouraged by this first experience, decided to still innovate and supply the market the right tools by creating Open Loop Hall Effect transducer families based on a dedicated ASIC.

The market already has plenty of experience with ASICs based on Hall Effect (fig. 2), the goal was not to create a similar product just dedicated for O/L current transducers.

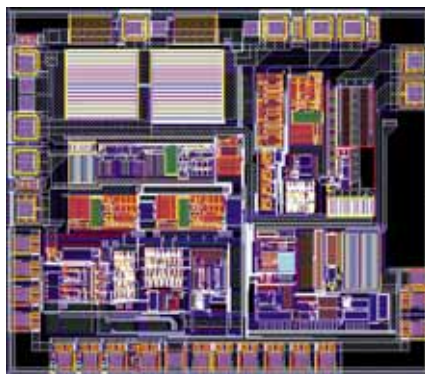

Fig 2. LEM ASIC with Hall effect cells.

It was necessary to find the "plus" making this ASIC unique and unchallenged, answering to requirements never before supplied by any ASIC, such as better accuracy, drifts, or behaviours in disturbed environments. These were the criteria to make this ASIC part of the change of the existing applications.

Current measurement in the power electronic applications

The use of digital control components such as microprocessors revolutionized the power electronics world. This was the start of a new step allowing better control, monitoring and protection by using less performing components at a lower cost. The goal being to ensure the best control through a main tool : the microprocessor associated with the A/D converter (often integrated to the microprocessor).

They have been the success factor for low cost, high performance new generation of drives for instance.

Two main goals were :

1. to have the linked devices working at the same voltage level (0 to +5 Volts) as the microprocessor and/or the A/D converter and

2. to maintain low current consumption. Indeed, the current available for components consumption is quite limited in general (about some mA).

Lower cost can also be achieved by the use of ratiometric microprocessors requiring the use of ratiometric peripheral devices (in some applications more dedicated for detection than for control).

The use of these new components provides compatibility with associated components which were previously not so accurate.



Fig 1. LTSR transducer for 6, 15 and 25 A_{RMS} nominal.

For example, initial offset for current measurement can be calculated out during the system initialisation.

It is the same for some other parameters such as the reference voltage. Therefore, the use of common reference voltages for the surrounding components allows better control and precision of the total accuracy. This is valid for the reference voltage offset and its drift.

Besides the technical aspects, lowering the cost was another requirement. As technology costing the less, Open Loop hall effect technology has already proven itself as a low current consumption transducer.

Many other possibilities have been considered and analysed such as GMR (Giant Magneto Resistance), or existing integrated circuits. However these devices exhibit unpredictable behaviours after overloads (hysteresis) or non-linearity and unstable behaviour after surge currents.

With this in mind, we believe the best compromise is the combination of **Open Loop Hall effect technology** and a dedicated **ASIC** making it suitable for the needed features new components require in Power Electronic applications.

Many ASICs available in the market today allow easy integration to Open Loop hall Effect based current transducers. The introduction of the LTS/LTSR Closed Loop transducers with ASIC technology has already moved us one step forward: A unique transducer and very successful with new Power Electronics applications. Subsequently, for O/L current transducers, the building of an ASIC to match to the trend of the market had to be unique and provide higher performances of the available ASICs on the market dedicated for such functions.

Open Loop technology Reminder

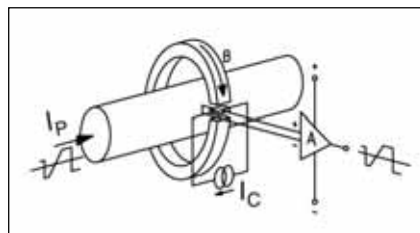

Fig 3. Principle of Open Loop Transducers.

For the isolated current measurement, Open Loop current transducers (fig.3) use a magnetic circuit with an air gap, located (without any galvanic contact) around the conductor which carries the current to be measured. A linear Hall element is inserted into the air gap and provides a Hall voltage proportional to the flux produced by the current. This Hall voltage is processed and buffered before being supplied at the transducer output.

Open Loop transducers offer a lot of benefits:

- Simple electronics.
In contrast to the Closed Loop transducers, no current is needed for the secondary winding, thus eliminating the need for a costly final amplifier power stage.

- Good price/performance ratio.
- Low power consumption.
- Small size for higher currents.

The disadvantages are:

- Relatively high offset and gain drift.
- Narrower frequency range. Up to 25 kHz and 50 kHz, based on the electronic performance and the quality of the magnetic circuit.
- Lower accuracy for the measurement of AC and DC currents.
- Overheating at high frequency currents due to magnetic hysteresis and eddy current losses.

Until now O/L current transducers were not able to be used in some applications due to their accuracy (offset drift, gain drift) and dv/dt behaviour, although their prices were certainly more attractive, as well as their size.

LEM designed a unique ASIC called "PASS" for O/L transducers bringing special improvements to these critical parameters.

One of the main challenges has been to compensate for various drifts (offsets and gain).

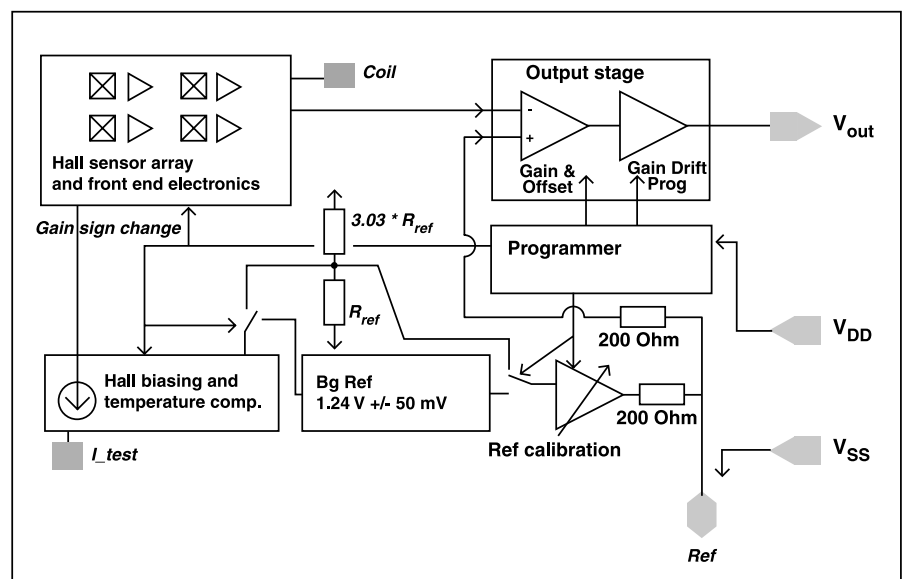

Fig 4. PASS ASIC fully designed by LEM O/L current transducers.

LEM PASS ASIC, main characteristics

The sensitive element, the Hall generator is designed directly into the silicon wafer which provides the analog amplification circuit as well as a digital programming module for offset and gain adjustment. Dynamic cancellation techniques allow cancellation of the offset and offset drift and other thermal compensation circuits, help obtain a stable gain. Finally, this led to an ASIC with the following features :

- + 5 Volt power supply
- Large sensitivity range from 0.55 to 4 mV/Gauss
- Ratiometric or fixed gain & offset programmability
- Vref IN/OUT on the same pin
- Electrostatic discharge protection on all the pins
- Short circuit protection on all the pins

The ASIC works with its own stable and accurate internal reference voltage (2.5 Volts) but is also able to work with an external reference voltage between 2 and 2.8 Volts.

The internal reference is available for the user on a separate pin and must be used with a minimum load of 200 kOhm. This reference voltage can then be monitored by the microprocessor system to compensate the sensor's initial offset at any time.

In the case where an external reference voltage is available, it can be used by connecting it to the reference pin. This external reference can be from the microprocessor or the A/D converter for example.

The reference can be shared between common users, meaning that the microprocessor knows in real time the reference used by the ASIC (and also then its drift which can then be compensated).

As the reference is part of the ASIC output signal, this is a way to remove all inaccuracy coming from the reference and to deal with only one reference for the whole application.

When connecting the reference pin to an external voltage there are some rules to respect. The external reference must be able to sink 2.5 mA (for an external reference = 2 Volts minimum) as current and to source 1.5 mA (for an external reference = 2.8 Volts maximum).

First case:

External reference of 2V connected to Vref of Transducer
 External reference must be able to sink $(2.5 V - 2 V) / 200 \text{ Ohm} = 2.5 \text{ mA}$

Second case :

External reference of 2.8V connected to Vref of Transducer
 External reference must be able to source $(2.8 V - 2.5 V) / 200 \text{ Ohm} = 1.5 \text{ mA}$

The use of the external reference can also limit your measuring range. When internal reference voltage is used, the transducers are usually expected to have a measuring span of up to +/- 3 x Ipn as required in drives applications (inverters, servos) for overload and short-circuit protection.

For a + 5 Volt power supply, and using the internal reference, the max voltage output is defined as being :
 $V_{out} = V_{ref} \times +/- 2 = 2.5 V \times +/- 2 \text{ volts}$.
 $V_{out} \text{ Min value} : + 0.5 \text{ volts}$.
 $V_{out} \text{ Max value} : + 4.5 \text{ Volts}$.

By using the external reference, this will then fix the initial offset, also fixing the measuring range.

The output voltage will swing around the initial offset +/- 2 volts (which is the max possible output voltage span) by staying above + 0.5 volts and below - 4.5 volts (limits not to cross).

Example 1 : By using 2 Volts as external voltage for the reference, the output could be:

- + 2 volts* + 2 Volts = + 4 Volts for the positive side
- + 2 volts* - 1.5 volts = + 0.5 volts for the negative side.

You will have only 1.5 Volts as negative current span limiting your negative measuring range.

Example 2 : By using 2.8 Volts as external reference voltage, the result would be the following :

- + 2.8 volts* + 1.7 Volts = + 4 Volts for the positive side. You will have only 1.7 Volts as positive current span limiting your positive measuring range.
- + 2.8 volts* - 2 volts = + 0.8 volts for the negative side.

The same logic can be applied when the offset defined is ratiometric.

Compared to traditional discrete components, the ASIC spans the operating temperature range from **-40°C to + 85°C** (and even up to **+ 105°C** for some of these new models).

This is particularly valuable in Forklift applications where warehouse temperatures are potentially extreme.

The transient response of the ASIC based transducer has been slightly modified

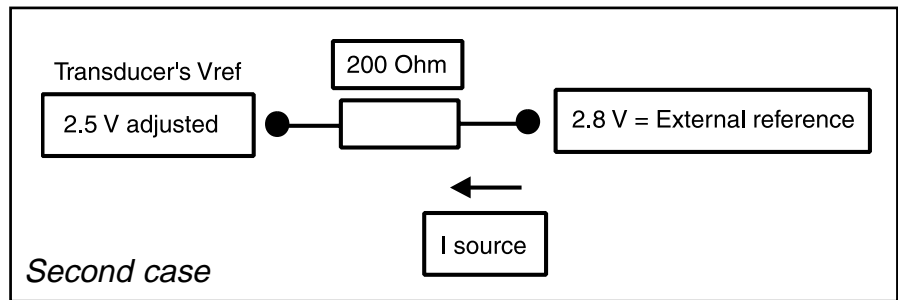
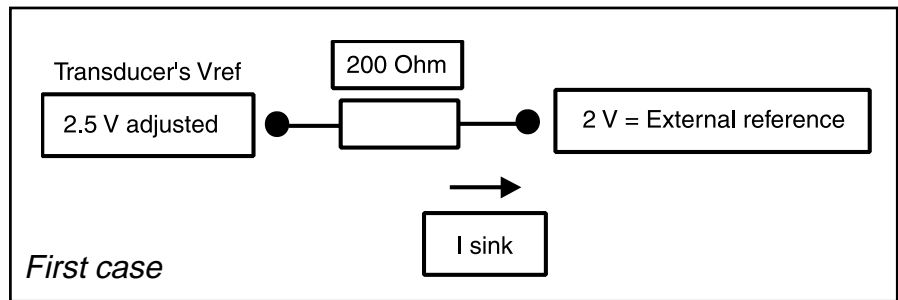

* (+ a certain tolerance)

compared with traditional Hall elements. The delay time in response to a transient with a di/dt of 100 A/μs is about 4 μs, as shown in Fig. 5. This duration is within reasonable limits to allow for short-circuit cut-off and also for the adjustment of a current circuit. The somewhat longer delay time can be explained by the dynamic cancellation techniques technology of the Hall cells, which is applied in order to improve the drift parameter.

Because of the dynamic cancellation, the noise at the sensor output increases by a factor of 3 in comparison with traditional Hall elements. Typically it is about 10 m Vpp, which corresponds to about 1.6% of the output nominal current. Because of the high frequency 500 kHz of the switching noise, this does not lead to impairment in the usual applications. With very fast current regulation circuits that require typically a high bandwidth, this parameter should be taken into consideration.

Another feature of the ASIC is the offset and gain programmability. Initially the offset is set at its optimum value and then the gain can be adjusted to the required value to have as much output signal through the defined measuring range. This is programmed during the manufacturing of the transducer. With only one ASIC, it has been possible to define several current ranges with nearly always the same voltage level at the output for the nominal defined currents.

Resulting from that, the introduction of not more than **3 new Open Loop LEM current transducer families** named as follows :

- HXS 20..50-NP** (Fig 6)
- HAI5 50..400-P** (Fig 17)
- HTFS 200...800-P** (Fig 22)

Design Tool

All using the same ASIC, they have been created to answer to the current measurement requirement in Power Electronic applications. For the **magnetic circuit design**, software simulating the three-dimensional flux has been used, allowing to choose the right material to achieve

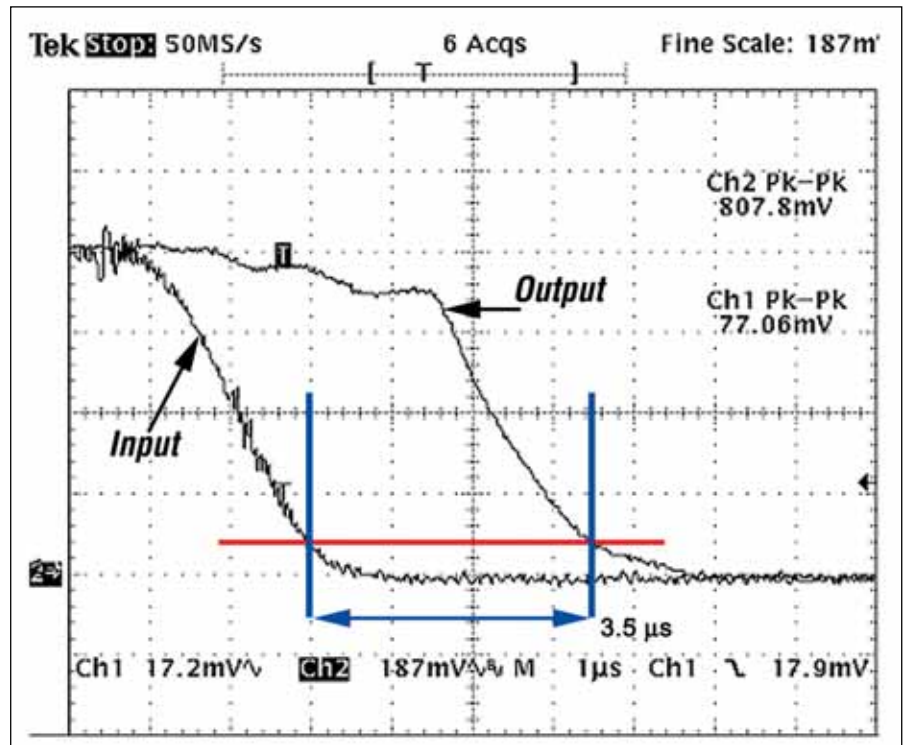

Fig 5. Dynamic behaviour upon a current transient.

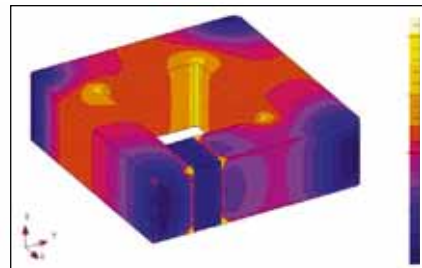

Fig 7. Flux simulation for the HXS magnetic circuit.

the desired dimensions (Fig. 7).

HXS 20..50-NP

100 % dedicated for PCB mounting, and very compact (18.5 x 16.5 x 10 mm), it integrates a multirange primary conductor.

Same pinout is used for the 20 A_{RMS} nominal version as for the 50 A_{RMS} nominal version providing use of the same model for a complete range of drives. According to the pinout configuration on the primary conductor busbar, you can configure it as a 5, 10 or 20 A_{RMS} nominal model for the HXS 20-NP or as a 12.5, 25 or 50 A_{RMS} nominal model for the HXS 50-NP.

The internal reference voltage is provided on a separate pin (*) or can be forced by

an external reference.

Gain and offset are fixed.

For the nominal current, the output is equal to the reference(*) used +/- 0.625 Volts.

Special Applications

A special model (HXS 10-NP/SP3) configured with **2 primary windings** (to be connected in series or parallel through the PCB pattern layout according to the need) offers the possibility to measure 3 phase inverter applications, using only a pair of transducers with 2 phases per transducer (Fig.8). No need for a third unit and another cost reduction is

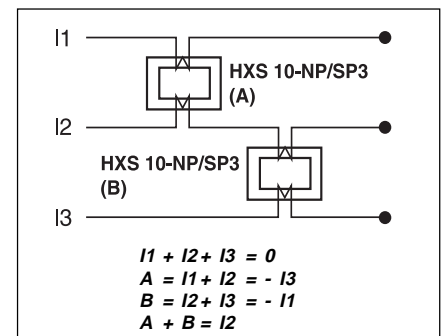

Fig 8. Measurement of 3-phase currents with only 2 transducers.

* (+ a certain tolerance)

HXS models, main characteristics

achieved. This model is specifically designed for this application by providing isolation between both the primaries. According to its primary windings configuration (series or parallel), the HXS 10-NP/SP3 allows a 10 or 20 A_{RMS} nominal measurement.

HXS 20-NP/SP30 has been developed for use with long shielded conductors and their associated capacitive currents and for **high frequency applications**. The normal heating of the magnet core has been dramatically reduced. The transducer is specially adapted for

frequency converters, Power Supplies and small UPS installations.

The use of this special magnetic circuit vs the HXS standard is a way to improve the frequency response of the transducer (Fig. 9, 10, 11, 12).

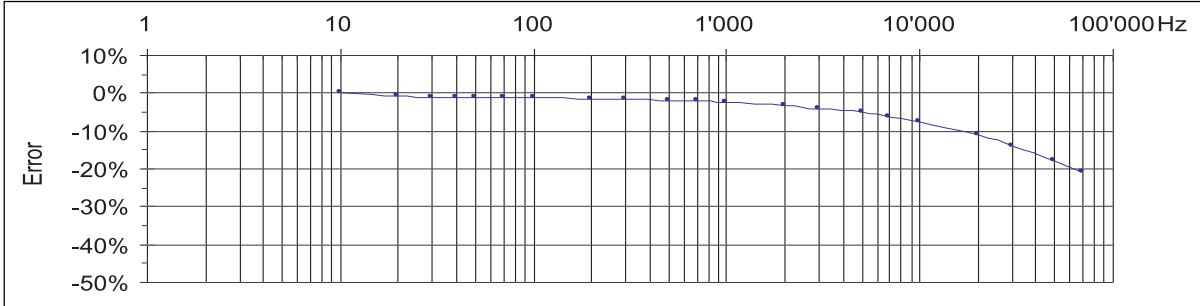

Fig 9. Frequency response of the HXS 20-NP.

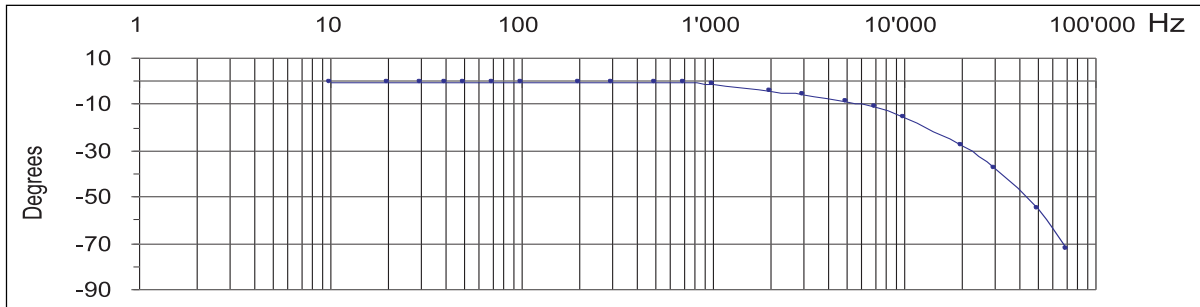

Fig 10. Phase shift of the HXS 20-NP.

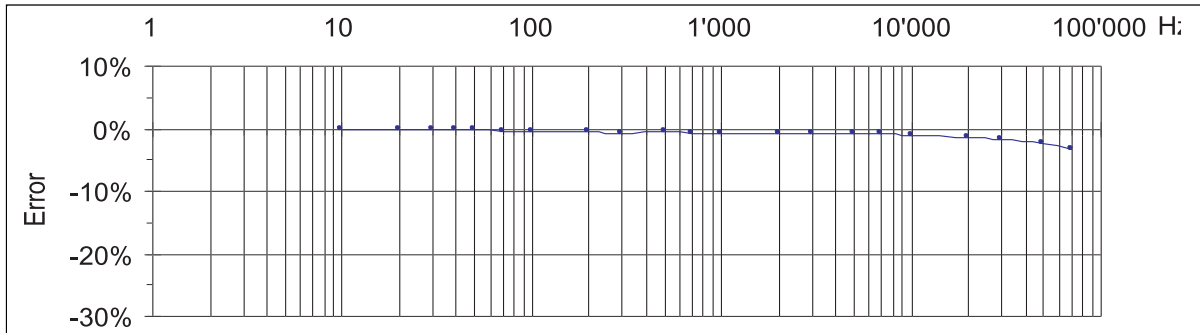

Fig 11. Frequency response of the HXS 20-NP/SP30.

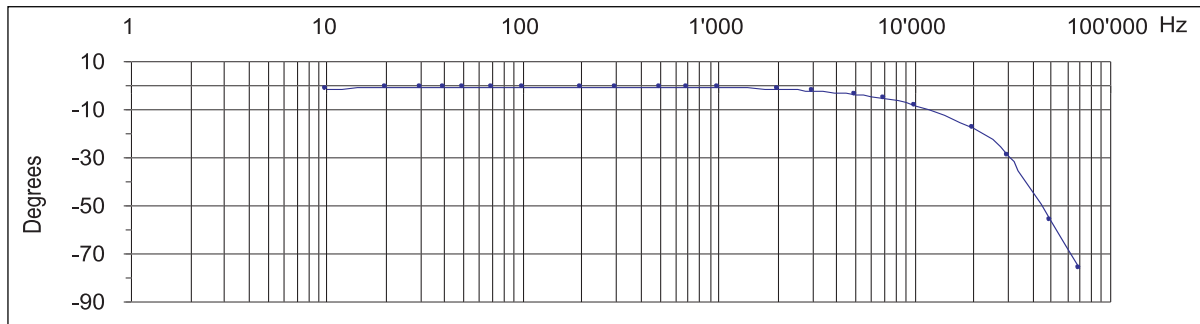

Fig 12. Phase shift of the HXS 20-NP/SP30.

HXS models, main characteristics

The solution to heating due to high frequencies can indeed be the HXS 20-NP/SP30. The other possibility to avoid this heating is to use the HXS standard models and to apply a certain derating for I_p vs Frequency (Fig. 13).

HXS 20...50-NP/SP2 are also available for higher operating temperature ranges (-40°C to +105°C instead of -40°C to +85°C).

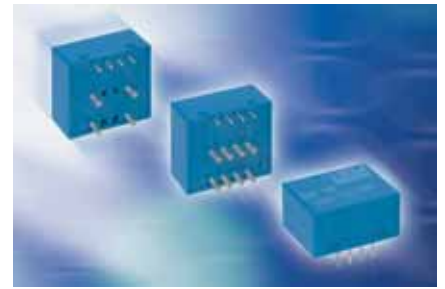

Fig 6. HXS models.

HXS main characteristics

Models	HXS 20-NP	HXS 50-NP	HXS 10-NP/SP3	HXS 20-NP/SP30
Particularity	Standard	Standard	Dual Phase	Special Core for Frequency heating
Primary Turns / Rating (I_{PN})	4 Turns / 20 A.t	4 Turns / 50 A.t	2 Turns / 20 A.t	4 Turns / 20 A.t
Measuring Range	60 A.t	150 A.t	60 A.t	60 A.t
Linearity	+/- 0.5 % of Reading			
Supply Voltage	+ 5 V (+/-5%)			
Output Voltage	$V_{ref} \pm (0.625 V \times I_p / I_{PN})$			
Reference Voltage	+ 2.5 V +/- 25 mV			
External Reference Voltage	From 2 to 2.8 Volts			
Accuracy	+/- 1%			
Residual Voltage after an Overload of $3 \times I_{PN}$ DC	+/- 0.7 %	+/- 1 %	+/- 0.7 %	+/- 1.2 %
Drift of (V_{out} / V_{Ref}) @ $I_p=0$	+/- 0.2 mV / K			
Drift of V Ref	+/- 0.01 % / K			
Drift of V_{out} @ $I_p=0$	+/- 0.4mV / K			
Drift of Gain	+/- 0.05 % of Reading/K			+/- 0.07% of Reading/K
Response Time @ 90 % of I_{PN}	5 μ s			
Operating Temperature	-40°C to +85°C			

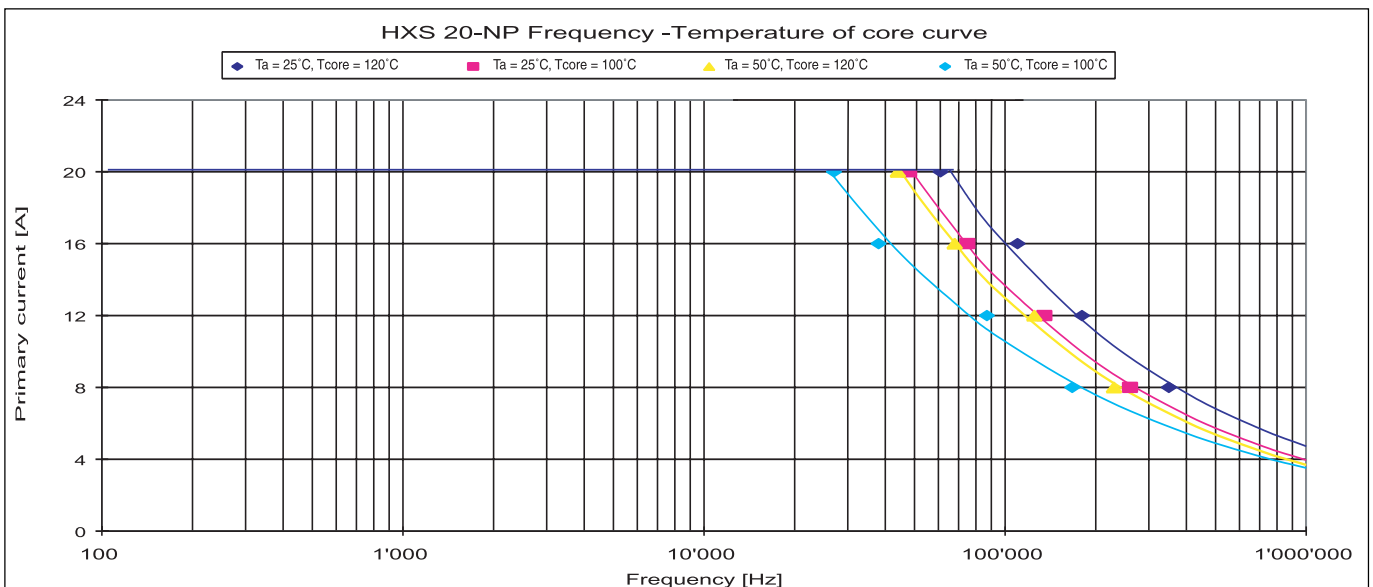

Fig 13. I_p vs Frequency derating curves for the HXS standard models.

Improvements brought by the ASIC on Open Loop current transducers

PASS ASIC is at the source of the accuracy improvement for the O/L current transducers. In Fig 14, you can notice the offset, gain drifts and linearity is improved by 2 times or more.

For the HXS models, the offset drift vs the

reference has been defined at max +/- 0.2 mV/K over the operating temperature range of -40 to +85°C (to +105°C for the SP2 models), this is confirmed by the qualification tests in Fig. 15.

The HXS response time @ 90 % of I_{PN} is defined by the ASIC response time as previously stated. Same value is reproduced as well by the other transducers (HAIS and HTFS models) working with this ASIC (Fig. 16).

	Traditional O/L transducer (HY model)	O/L ASIC based transducer (HXS model)
Consumption	+ 10 mA	+ 22 mA
Operating Temperature	- 10°C to +80°C	- 40°C to +85°C
Offset drift	0,075 %/K	0,032 %/K (Compared to Ref)
Linearity	1 %	0,5 %
Gain drift	0,1%/K (Of reading)	0,05%/K (Of reading)
Response time @ 90% of I_{PN}	3 μ s	5 μ s
Noise	10 mVpp	20mVpp High frequency

	Traditional O/L transducer (HTB model)	O/L ASIC based transducer (HAIS model)
Consumption	+ 15 mA	+ 22 mA
Operating Temperature	- 20°C to +80°C	- 40°C to +85°C
Offset drift	0,05 %/K	0,032 %/K (Compared to Ref)
Linearity	1 %	0,5 %
Gain drift	0,1%/K (Of reading)	0,05%/K (Of reading)
Response time @ 90% of I_{PN}	3 μ s	5 μ s
Noise	10 mVpp	20mVpp High frequency

Fig 14. Comparison between traditional O/L current transducer and O/L ASIC based current transducer (performance).

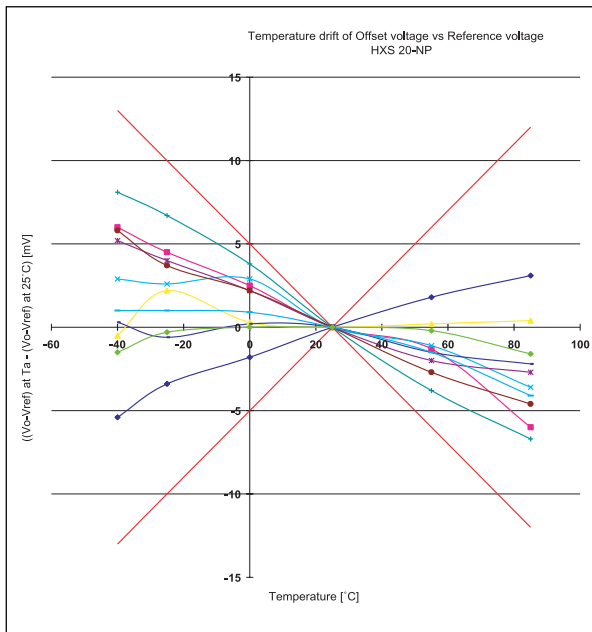

- ◆ Sample No 1
- Sample No 2
- ▲ Sample No 3
- ✕ Sample No 4
- ✱ Sample No 5
- Sample No 6
- ◆ Sample No 7
- Sample No 8
- Sample No 9
- ◆ Sample No 10
- TCVout/Vref: ±0,2[mV/K]

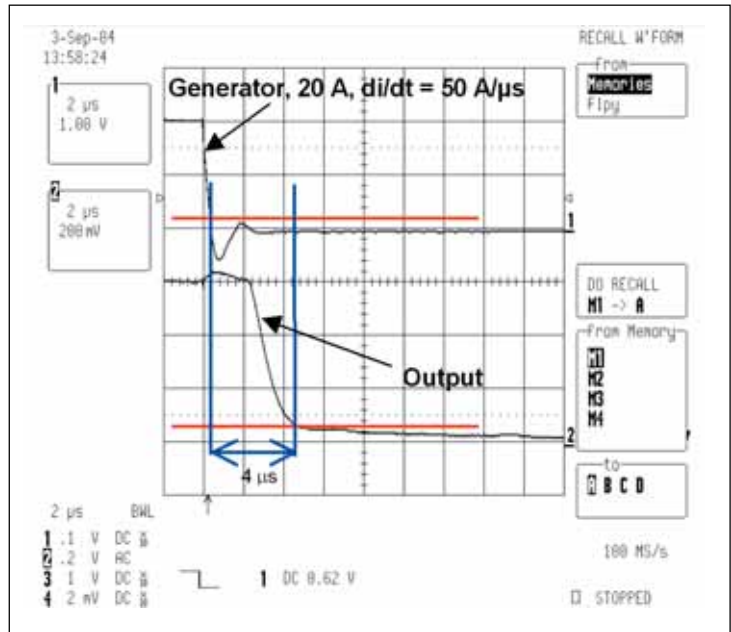

Fig 16. HXS 20-NP response time @ 90 % of I_{PN} ($I_P = 20$ A, $di/dt = 50$ A/ μ s).

Fig 15. Temperature drift of the HXS 20-NP offset voltage.

HAIS models, main characteristics

HAIS 50...100-TP and HAIS 50...400-P

Only available for 50 and 100 A_{RMS} nominal, the TP versions are 100 % dedicated for PCB mounting using an integrated primary busbar as the primary conductor.

The same pinout is used for all the HAIS -P models made up to 5 devices to cover a nominal measuring range from 50 A_{RMS} to 400 A_{RMS} and using a square aperture (15 x 8 mm) for the primary conductor.

The PCB mounting is firmly secured by two round metallic pins, one of which also serves as a ground connection to provide better immunity to common mode noise, found in most switching environments, and to improve the EMC behaviour.

As for the HXS models, the reference voltage (internal or external) is found at the output for no primary current (*). Gain and offset are fixed.

For the nominal current of all the HAIS models, the output is equal to the reference used (*) +/- 0.625 Volts.

HAIS models respond to safety isolation requirements up to 600 V nominal voltage (Overvoltage category III, Pollution degree 2).



Fig 17. HAIS xx-P models at the top and HAIS xx-TP at the bottom.

HAIS main characteristics

Model	HAIS 50-P or -TP	HAIS 100-P or -TP	HAIS 150-P	HAIS 200-P	HAIS 400-P
Rating (I _{PN})	50 A	100 A	150 A	200 A	400 A
Measuring Range	150 A	300 A	450 A	600 A	600 A
Linearity	+/- 0.5% of Reading				
Supply Voltage	+ 5V (+/- 5%)				
Output Voltage	Vref +/- (0.625V x I _P / I _{PN})				
Reference Voltage	+ 2.5V +/- 25 mV				
External Reference Voltage	From 2 to 2.8 Volts				
Accuracy	+/-1 %				
Drift of (Vout / V Ref) @ I _P =0	+/- 0.2 mV/K				
Drift of V Ref	+/- 0.01 %/K				
Drift of Vout @ I _P =0	+/- 0.3 mV/K				
Drift of Gain	+/- 0.05 % of Reading/K				
Response Time @ 90 % of I _{PN}	5μs				
Operating Temperature	- 40°C to + 85°C				

* (+ a certain tolerance)

Wide frequency bandwidth

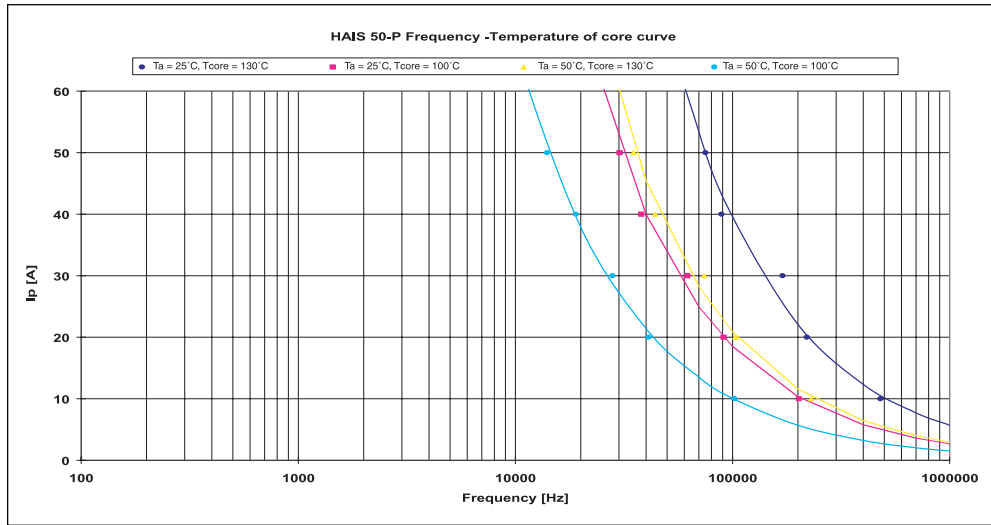

Fig 18. I_p vs Frequency derating curves for the HAIS models.

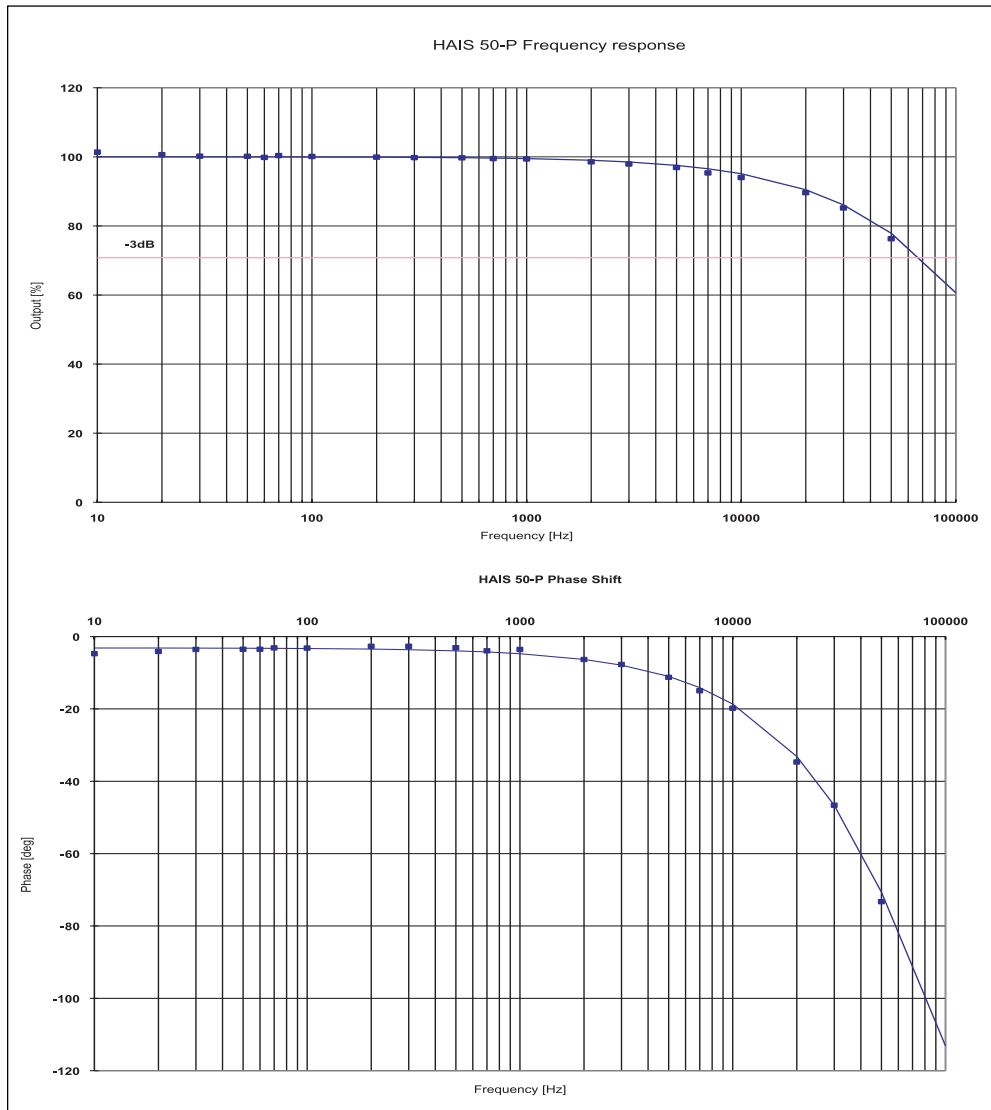

Fig 19. Frequency and phase response of the HAIS 50-P.

HTFS 200 - 400 - 800-P

3 models rated for 200, 400 and 800 A_{RMS} nominal current, to be mounted on PCB but with a round aperture of 22 mm diameter for the primary conductor. The same mechanical design for the 3 models. The reference voltage (internal or external) is the output at zero primary current (*) as with the HXS and H AIS models.

For the nominal current of all the HTFS models, the output is equal to the reference used (*) +/- 1.25 Volts. However, when the gain is fixed, the initial offset is ratiometric and equal to V_{cc}/2 (*), a constraint in forklift applications, as an example.

Forklift application

This model is specially designed for use in Forklift drive control systems. Typically, 2 of these transducers are monitoring and measuring the currents supplied to 2 of the 3 phases of an AC motor driving the truck or lift pump.

The signals provided by the transducers are processed and analyzed (giving indication of the speed state in real time) by intelligent control cards made up of A/D converters, microprocessors... taking also into account the speed signal required by the driver (typically the signal coming from the electronic throttle) and the speed signal feedback from sensorised bearing to provide a PWM signal, going through a power electronic amplifier supplying the AC motor.

The Forklift speed is then controlled via the current supplied to the AC motor.

All the on-board electronics are powered from the DC battery (Fig. 20).

The transducers selected must be able to be used with microprocessors in an easy way (matching with power supply levels, type of output signal to feed the microprocessor input, references used...with no additional components) and HTFS models answer completely to this kind of request.

The transducer has extremely robust mechanics and can be fastened to the printed circuit either with solder pins (SP2 models) or with screws (standard HTFS models). It is remarkably adapted for battery-powered vehicles, such as forklifts or hybrid excavators.

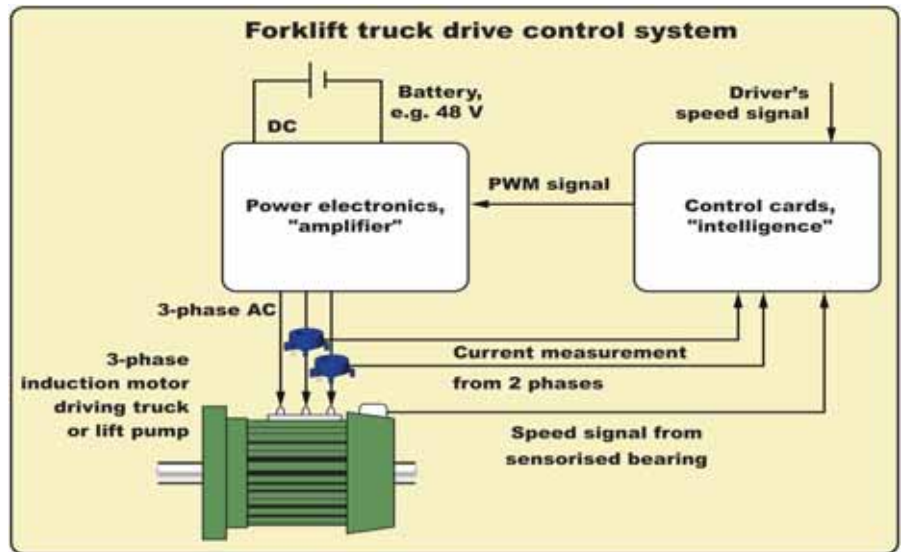

Fig 20. Forklift truck drive control system ensured by HTFS models.

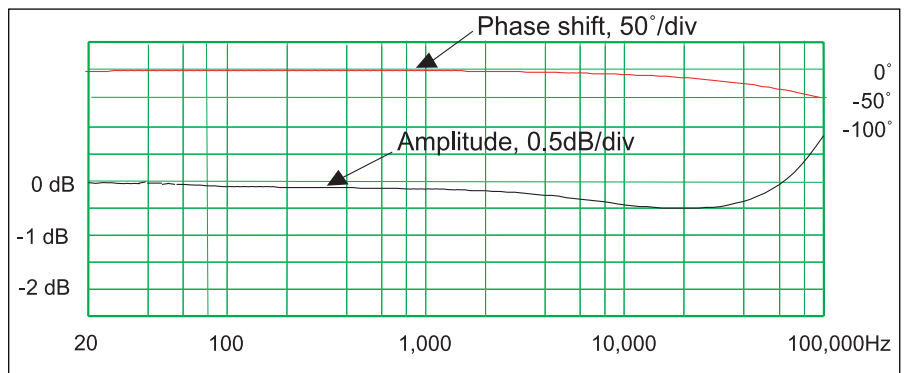

Fig 21. Frequency and phase response of the HTFS 400-P.

HTFS main characteristics

Model	HTFS 200-P	HTFS 400-P	HTFS 800-P
Rating	200 A	400 A	800 A
Measuring Range	300 A	600 A	1200 A
Linearity	+/- 0.5 % of Reading		
Supply Voltage	+ 5V (+/- 5%)		
Output Voltage	V _{ref} +/- (1.25V x I _P / I _{PN})		
Reference Voltage	V _c /2 +/- 25 mV		
External Reference Voltage	From 2 to 2.8 Volts		
Accuracy	+/- 1%		
V _{out} Drift @ I _P = 0	+/- 0.3 mV/K		
Offset Drift (V _{out} vs V _{ref}) @ I _P = 0	+/- 0.2 mV/K		
Gain Drift	+/- 0.05 % of Reading /K		
Response Time @ 90 % of I _{PN}	5 μs		
Operating Temperature	- 40°C to +105°C		

* (+ a certain tolerance)



Fig 22 : HTFS xxx-P models

The heart of these 3 transducer families is the unique PASS ASIC designed by LEM allowing all these features such as:

- Fixed initial offset and gain, or
- Fixed gain and ratiometric offset, or
- Different gains at different nominal currents, or
- Internal reference available outside or external reference used internally according to customer choice.

It has also been possible to improve the drift of the gain, the drift of the offset just by digital programming of the ASIC during the transducer manufacturing.

The use of ASIC, to improve O/L transducer performance combined with the usual attractive pricing of O/L transducers makes the O/L ASIC based transducers much more desirable than solutions of the past.

The ASIC used inside the transducer also makes it a more reliable device.

Traditionally, the Open Loop electronics was made as a discrete circuit that normally involved a large number of components, connections, solder points...

A typical figure for the potential causes of defect is nearly 100. This is to be compared with less than 10 for a similar ASIC based transducer: an improvement of more than ten. From a purely mathematical point of view, this implies a much better **MTBF**.

Software calibration eliminates human error !

Potentiometers are no longer used for calibration, still another source of potential defect erased from the manufacturing process, we increase also the vibration withstanding ability of the transducer.

As a matter of fact, our field defect figure for a similar ASIC based product, launched a couple of years ago is less than 60 ppm.

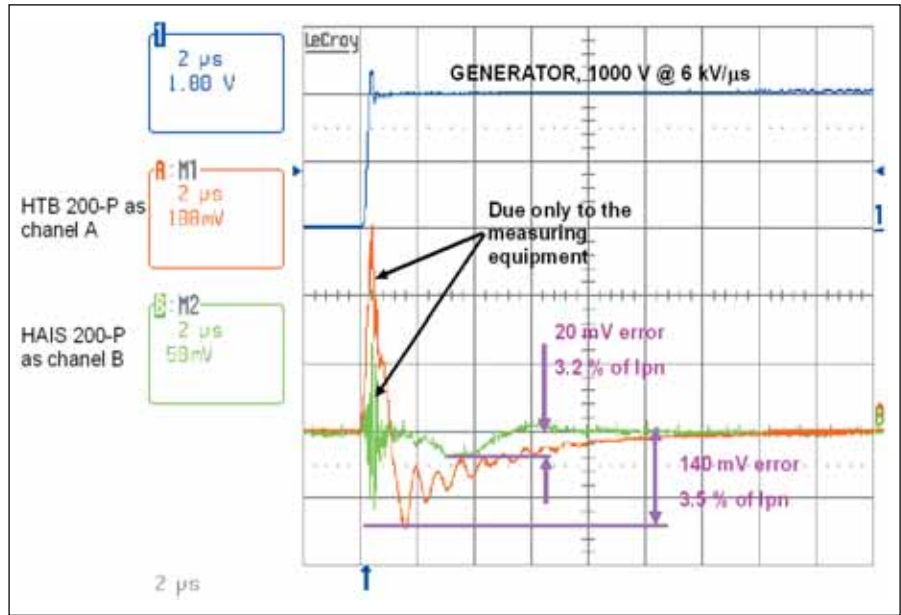

Fig 23. Comparison between traditional O/L current transducer (HTB 200-P model) and O/L ASIC based current transducer (HAIS 200-P model) (dV/dt behaviour) (dV/dt = 6 kV/μs, 1000 V applied).

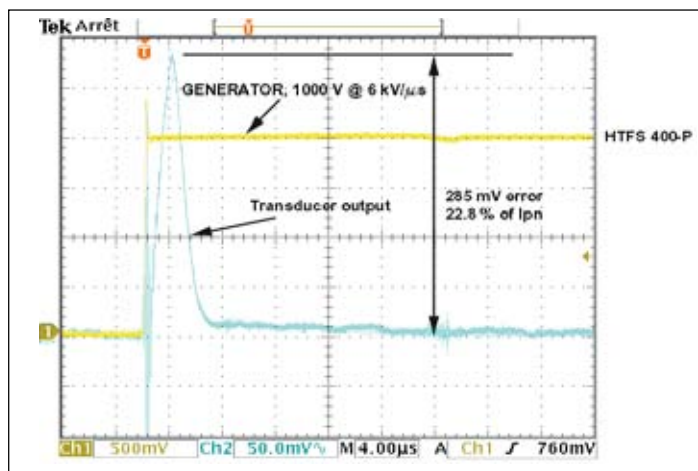
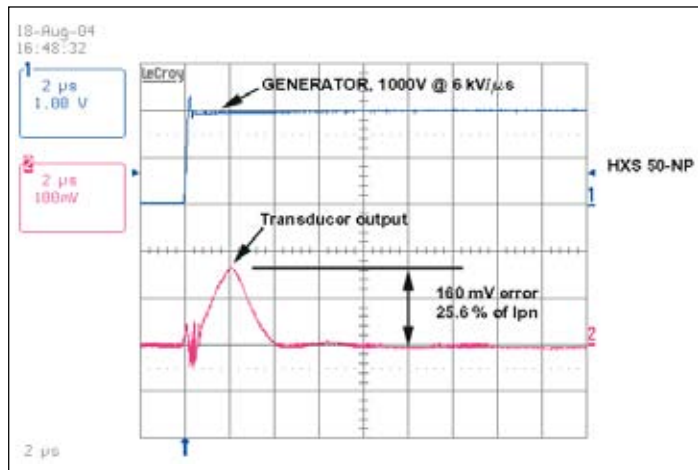

Fig 24. HXS 50-NP and HTFS 400-P : Behaviour against dV/dt = 6 kV/μs, 1000 V applied.

Behaviour at dV/dt noise and some application advices

This ASIC has been designed for high EMC withstanding and immunity against dV/dt (Fig 23) and disturbed environments. Common mode noises (dV/dt) are often encountered in applications using fast switching components like IGBTs. Inverters are the perfect example of that, as they tend to operate at high switching frequency, 20 kHz or more for better efficiency. However, the dV/dt results in a capacitive current between the primary conductor and the electronic circuit of the transducer. The transducers with all the electronic components inside are sensitive to this phenomena. This noise will be superimposed on the transducer output signal creating some error on the normal output. According to the error induced, this could easily lead to activations of a current protection circuit in the application causing the inverter to shut down. Level shifting or error by the transducer during the dV/dt is then a parameter to take into account during the design of the inverter for example (Fig. 24).

A high frequency signal noise filter can be installed by the user at the transducer output to limit this noise. Values of the filter (R1 & C1) have to be defined by the user according to the application

bandwidth need (nevertheless, for optimum transducers performance, the resistance value R1 must be ≥ 100 Ohm and the capacitor value C1 can be up to 1 μ F. Fig. 25 : in red colour).

Best performances are ensured with some application recommendations (Fig 25).

The transducer mounted on printed circuit should be associated as closely as possible, with some ceramic capacitors. These capacitors contribute notably to the improvement of the EMC behaviour. Fig. 25 shows the cabling with the values found in practice during measurements. This can however, be somewhat different based on application. The reference should have the same value as the supply voltage.

Standards

All these devices conform to EN 50178 (standard for industrial applications) and EN 61010-1 (safety).

They are CE marked in accordance with European EMC Directive 89/336/EEC and thus comply with local EMC regulations.

UL recognition is in progress for all models. All transducers respond to the EU guidelines RoHS that come into force July 1st 2006.

Conclusion

This new generation of current transducers from LEM Components provides an ideal solution for the new requirements of Power Electronics to get more synergy between all the components of the systems. They bring the necessary interfaces between the current capture and the signal processing, leading to a simplification of the whole process with less intermediate converters.

Based on over 30 years experience in the world of electrical measurement, LEM Components is dedicated to developing and adapting new technologies to the continually changing demands of this market and this is why LEM is truly "Made to Measure".

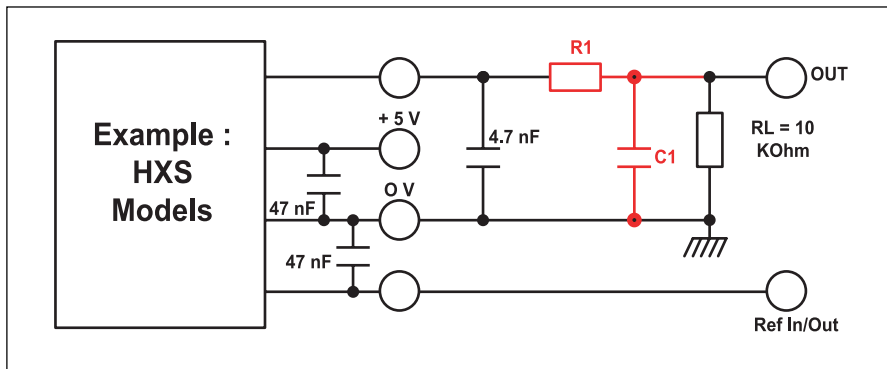

Fig 25. Application recommendations for HTFS, HAIS & HXS models.

Current Transducers



HXS 10-NP/SP3
HXS 20..50-NP
HAIS 50..400-P
HAIS 50..100-TP
HTFS 200..800-P

$I_{PN} = 10 \text{ A}$
 $I_{PN} = 5-10-12.5-20-25-50 \text{ A}$
 $I_{PN} = 50..400 \text{ A}$
 $I_{PN} = 50..100 \text{ A}$
 $I_{PN} = 200-400-800 \text{ A}$

For the electronic measurement of currents : DC, AC, pulsed, mixed, with a galvanic isolation between the primary circuit (high power) and the secondary circuit (electronic circuit).

All data are given with a $R_L = 10 \text{ k}\Omega$

Electrical data

Primary nominal r.m.s. current $I_{PN} \text{ (A)}$	Primary current measuring range $I_P \text{ (A)}$	Type
20	± 60	HXS 20-NP
20	± 60	HXS 20-NP/SP30 (design to avoid heating in high frequency)
50	± 150	HXS 50-NP
50	± 150	HAIS 50-P, HAIS 50-TP ¹⁾
100	± 300	HAIS 100-P, HAIS 100-TP ¹⁾
150	± 450	HAIS 150-P
200	± 600	HAIS 200-P
400	± 600	HAIS 400-P
200	± 300	HTFS 200-P
400	± 600	HTFS 400-P
800	± 1200	HTFS 800-P

Serial	Parallel	Serial	Parallel
± 10	± 20	± 30	± 60

(dual phase) **HXS 10-NP/SP3**



		HAIS Series	HXS Series	HTFS Series	
V_{OUT}	Analog output voltage @ I_P	$V_{REF} \pm (0.625 \cdot I_P / I_{PN})$	$V_{REF} \pm (0.625 \cdot I_P / I_{PN})$	$V_{REF} \pm (1.25 \cdot I_P / I_{PN})$	V
	$I_P = 0$	$V_{REF} \pm 0.025$	$V_{REF} \pm 0.0125$	$V_{REF} \pm 0.025$	V
V_{REF}	Internal Reference ²⁾ -Output voltage	2.5 ± 0.025	2.5 ± 0.025	$1/2 V_c \pm 0.025$	V
	V_{REF} Output impedance	typ. 200	typ. 200	typ. 200	Ω
	V_{REF} Load impedance	≥ 200	≥ 200	≥ 200	k Ω
R_L	Output load resistance	≥ 2	≥ 2	≥ 2	k Ω
R_{OUT}	Output impedance	< 10	< 10	< 10	Ω
C_L	Output capacitive load	up to 1	up to 1	up to 1	μF
V_c	Supply voltage ($\pm 5 \%$)	5	5	5	V
I_c	Current consumption @ $V_c = 5 \text{ V}$	22	22	22	mA

Accuracy - Dynamic performance data		HAIS Series	HXS Series	HTFS Series	
X	Accuracy ³⁾ @ I_{PN} , $T_A = 25^\circ\text{C}$	$\leq \pm 1$	$\leq \pm 1$	$\leq \pm 1$	% of I_{PN}
ϵ_L	Linearity error 0 .. I_{PN}	$\leq \pm 0.5$	$\leq \pm 0.5$	$\leq \pm 0.5$	% of reading
	.. $3 \times I_{PN}$	---	$\leq \pm 1$	---	% of reading
TCV_{OUT}	Thermal drift of V_{OUT} @ $I_P = 0$	$\leq \pm 0.3$	$\leq \pm 0.4$	$\leq \pm 0.3$	mV/K
TCV_{REF}	Thermal drift of V_{REF}	$\leq \pm 0.01$	$\leq \pm 0.01$	$\leq \pm 0.01$	%/K
TCV_{OUT/V_{REF}}	Thermal drift of V_{OUT}/V_{REF} @ $I_P = 0$	$\leq \pm 0.2$	$\leq \pm 0.2$	$\leq \pm 0.2$	mV/K
TCE_G	Thermal drift of the gain	$\leq \pm 0.05$	$\leq \pm 0.05$ ⁵⁾	$\leq \pm 0.05$	% of reading/K
V_{OM}	Residual voltage @ $I_P = 0$, after an overload of $3 \times I_{PN DC}$	$< \pm 0.4$	$< \pm 0.7$ ⁶⁾	$< \pm 0.5$	% of I_{PN}
t_{ra}	Reaction time @ 10 % of I_{PN}	< 3	< 3	< 3	μs
t_r	Response time @ 90 % of I_{PN}	< 5	< 5	< 5	μs
di/dt	di/dt accurately followed	> 100	> 50	> 100	A/ μs
	Output noise without external filter (500 kHz)	< 20	< 20	< 20	mVpp
f	Frequency bandwidth (- 3 dB) ⁴⁾	DC .. 50	DC .. 50	DC .. 20	kHz

Notes : ¹⁾ - TP version is equipped with a primary bus bar.

²⁾ It is possible to override V_{REF} with an external reference voltage between 2 - 2.8 V providing its ability to sink or source approximately 2.5 mA.

³⁾ Excluding offset and hysteresis.

⁴⁾ Small signal only to avoid excessive heatings of the magnetic core.

⁵⁾ $\leq \pm 0.07 \%$ of reading/K for HXS 20-NP/SP30.

⁶⁾ $< \pm 1 \%$ for HXS 50-NP & $< \pm 1.2 \%$ for HXS 20-NP/SP30.

General data		HAIS Series	HXS Series	HTFS Series
T_A	Ambient operating temperature	- 40 .. + 85	- 40 .. + 85	- 40 .. + 105 °C
T_S	Ambient storage temperature	- 40 .. + 85	- 40 .. + 85	- 40 .. + 105 °C
dCp	Creepage distance	> 8	> 5.5	> 4 mm
dCl	Clearance distance	> 8	> 5.5	> 4 mm
CTI	Comparative tracking index UL94 classification	> 600 (Group I) V0	> 600 (Group I) V0	> 220 (Group IIIa) V0
m	Mass (in brackets : TP version) Standards	20 (30) EN 50178 : 1997	10 EN 50178 : 1997	60 EN 50178 : 1997

Insulation category		HAIS Series	HXS Series	HTFS Series
V_b	Nominal Voltage with IEC 61010-1 standards and following conditions - Single insulation - Over voltage category III - Pollution degree 2 - Heterogeneous field	300	150	150 V r.m.s.
V_b	Nominal Voltage with EN 50178 standards and following conditions - Reinforced insulation - Over voltage category III - Pollution degree 2 - Heterogeneous field	600	300	150 V r.m.s.
V_d	R.m.s. voltage for AC isolation test, 50/60 Hz, 1 mn	2.5	2.5 ⁷⁾	2.5 kV
V_e	R.m.s. voltage for partial discharge extinction @ 10 pC HAIS 50 ...400-P HAIS 50 ...100-TP	> 1 > 1.4	> 1	> 1 kV kV
\hat{V}_w	Impulse withstand voltage 1.2/50 μ s If insulated cable is used for the primary circuit, the voltage category could be improved with the following table :	8	6	4 kV
	Cable insulation (primary)	Category		Category
	HAR 03	450V CAT III	---	300V CAT III
	HAR 05	550V CAT III	---	400V CAT III
	HAR 07	650V CAT III	---	500V CAT III

Note : ⁷⁾ For HXS 10-NP/SP3: Primary to Secondary 2.5 kV, Primary 1 to Primary 2.5 KV.

Features

- Hall effect measuring principle
- Galvanic isolation between primary and secondary circuit
- Isolation test voltage 2500 V
- Low power consumption
- Single power supply + 5 V
- Multirange current transducer through PCB pattern lay-out (HXS series)
- Extremely low profile, 10 mm (HXS series)
- Fixed offset & gain (HAIS & HXS models)
- Fixed gain, ratiometric offset (HTFS models)
- Bus bar version available for 5 A and 100 A ratings (HAIS)
- $T_A = - 40 .. + 105^\circ\text{C}$ (HTFS models).

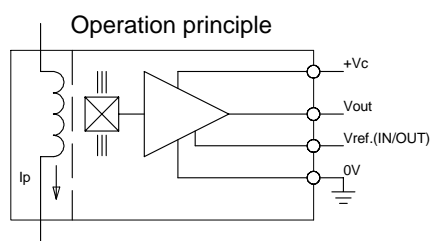

Advantages

- Small size and space saving
- High immunity to external interference
- V_{REF} IN/OUT (internal and external reference).

Applications

- AC variable speed drives and servo motor drives
- Static converters for DC motor drives
- Battery supplied applications
- Uninterruptible Power Supplies (UPS)
- Switched Mode Power Supplies (SMPS)
- Power supplies for welding applications
- Forklift drives
- Golf cars
- Wheel chairs
- Solar panel inverters.

LEM reserves the right to carry out modifications on its transducers, in order to improve them, without previous notice.

Safety



Caution, risk of danger



Caution, risk of electrical shock

"These transducers must be used in accordance with the following manufacturer's operating instructions.

The temperature of the primary conductor must not exceed 100° C (HAIS & HXS models). The power supply must be a low voltage source and must have efficient means of protection from overcurrents.

The power supply must have a circuit breaker protection.

This transducer must be used in electric/electronic equipment with respect to applicable standards and safety requirements.

When operating the transducer, certain parts of the module can carry hazardous voltage. Ignoring this warning can lead to injury and/or cause serious damage.

This transducer is a built-in device, whose conducting parts must be inaccessible after installation.

A protective housing or additional shield must be used"

HAIS 50..400-P

Front view

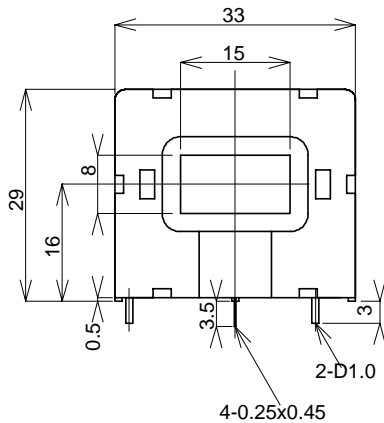

Bottom view

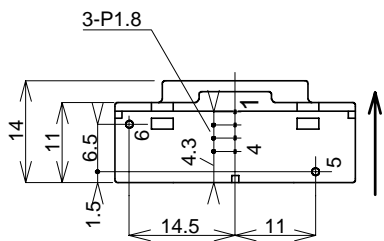

Terminal Pin Identification

- 1...+5V
- 2...0V
- 3...OUTPUT
- 4...Vref. (IN/OUT)
- 5...Core Earth (*)
- 6...NC.

HAIS 50..100-TP

Front view

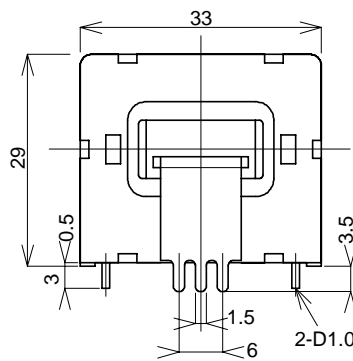

Bottom view

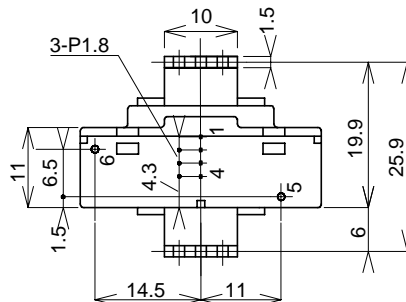

Right view

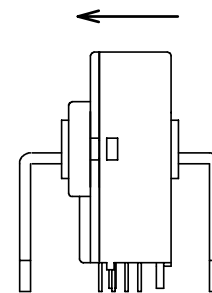

Recommended PCB hole

- Pin 1-4 : 0.7 ± 0.1mm
- Pin 5-6 : 1.5 ± 0.1mm
- Primary bus bar : 2.3 ± 0.1mm

General tolerance : ± 0.2mm

Unit : mm

(*) should be connected to 0V of Power Supply for better dv/dt immunity.
Arrow indicates positive current direction.

HXS 20 & 50-NP, HXS 20-NP/SP30 Dimensions (in mm)

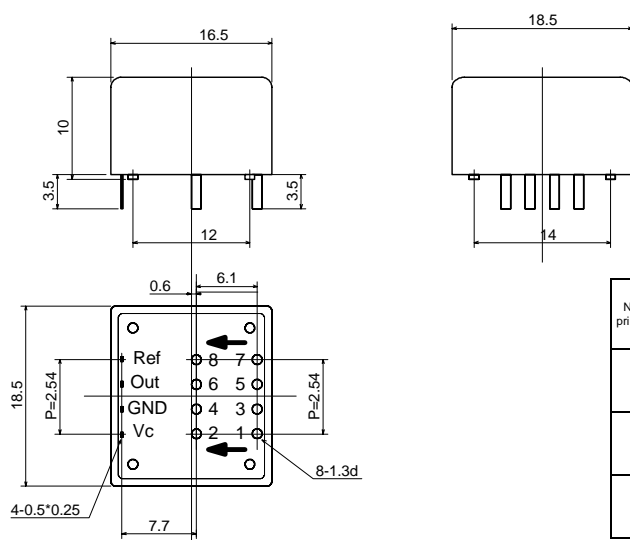

Number of primary turns	Primary current		Primary resistance R_p (m ohm)	Primary insertion inductance L_p (μ F)	Recommended PCB connections	Model
	nominal I_{FN} (A)	maximum I_p (A)				
1	20	60	0.05	0.025		HXS 20-NP & HXS 20-NP/SP30
	50	150				HXS 50-NP
2	10	30	0.20	0.100		HXS 20-NP & HXS 20-NP/SP30
	25	75				HXS 50-NP
4	5	15	1.00	0.400		HXS 20-NP & HXS 20-NP/SP30
	12.5	37.5				HXS 50-NP

Mechanical characteristics

- General tolerance ± 0.2 mm
- Fastening & connection of primary jumper 8 pins $\varnothing 1.3$ mm
Recommended PCB hole $\varnothing 1.5$ mm
- Fastening & connection of secondary 4 pins 0.5×0.25
Recommended PCB hole $\varnothing 0.7$ mm

Remarks

- V_{OUT} is positive when I_p flows from terminals 1, 3, 5, 7 (IN) to terminals 2, 4, 6, 8 (OUT).
- Temperature of the primary conductors should not exceed 100°C .

HXS 10-NP/SP3 (Dual phase measurement with 2 separate primary windings) Dimensions (in mm)

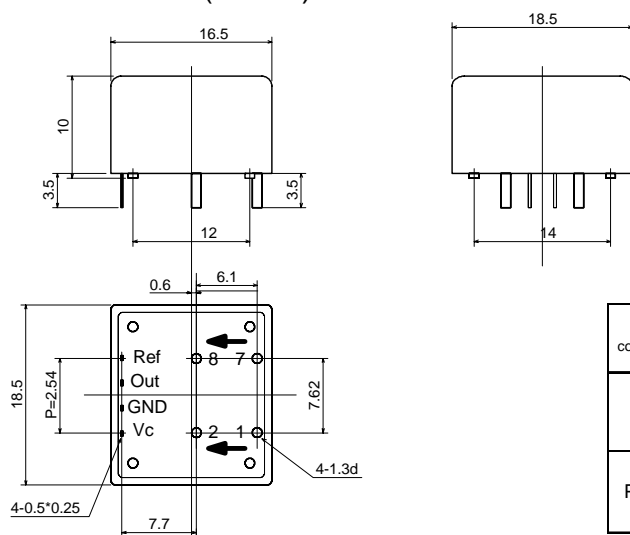

Primary connections	Primary current		Primary resistance R_p (m ohm)	Primary insertion inductance L_p (μ F)	Recommended PCB connections
	nominal I_{FN} (A)	maximum I_p (A)			
Serial	10	30	0.50	0.025	
Parallel	20	60	0.15	0.010	

Mechanical characteristics

- General tolerance ± 0.2 mm
- Fastening & connection of primary jumper 4 pins $\varnothing 1.3$ mm
Recommended PCB hole $\varnothing 1.5$ mm
- Fastening & connection of secondary 4 pins 0.5×0.25
Recommended PCB hole $\varnothing 0.7$ mm

Remarks

- V_{OUT} is positive when I_p flows from terminals 1, 7 (IN) to terminals 2, 8 (OUT).
- Temperature of the primary conductors should not exceed 100°C .

HTFS 200..800-P (Fixation by M3 nuts & screws)

Dimensions (in mm)

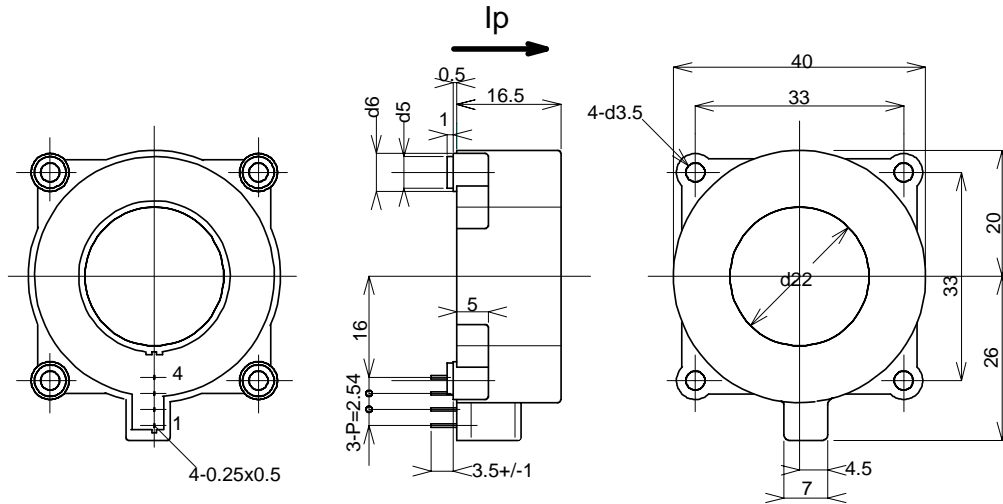

Mechanical characteristics (HTFS 200 .. 800-P)

- General tolerance ± 0.2 mm
- Fixation by 4 x M3 (not supplied)
- Recommended fastening torque < 2.5 Nm
- Fastening & connection of secondary 4 pins 0.5 x 0.25
Recommended PCB hole $\varnothing 0.7$ mm

Remarks

- V_{OUT} is positive when I_p flows in the direction of the arrow.
- Temperature of the primary conductor should not exceed 120°C.

Terminal Pin

- 1 .. +5 V
- 2 .. 0 V
- 3 .. Output
- 4 .. V_{REF} (IN/OUT)

HTFS 200..800-P/SP2 (PCB fixation)

Dimensions (in mm)

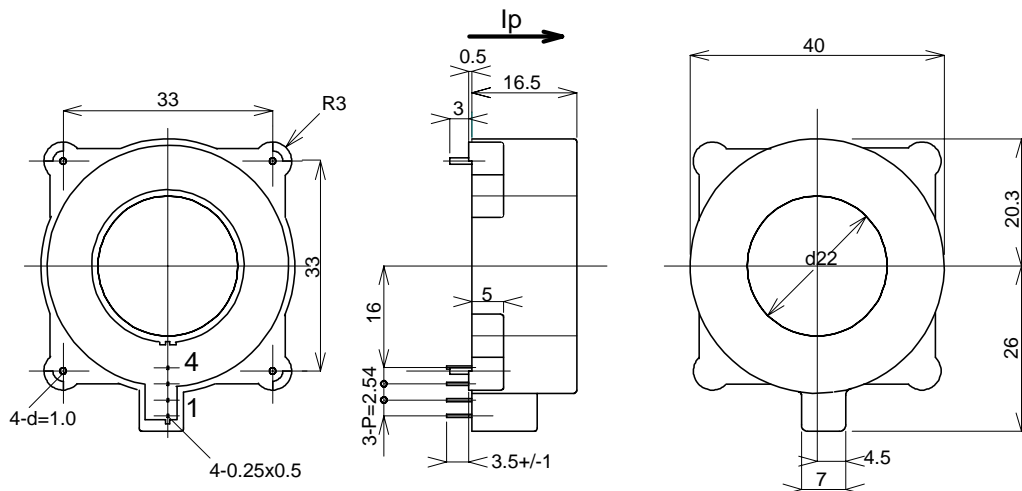

Mechanical characteristics (HTFS 200 .. 800-P/SP2)

- General tolerance ± 0.2 mm
- Fixation 4 pins x $\varnothing 1.0$
- Recommended PCB hole $\varnothing 1.2$ mm
- Fastening & connection of secondary 4 pins 0.5 x 0.25
Recommended PCB hole $\varnothing 0.7$ mm

Remarks

- V_{OUT} is positive when I_p flows in the direction of the arrow.
- Temperature of the primary conductor should not exceed 120°C.



5 Years Warranty on LEM Transducers

LEM designs and manufactures high quality and high reliability products for its customers over the entire world.

Since 1972, we have delivered several million current and voltage transducers which are, for most of them, still in operation on traction vehicles, industrial motor drives, UPS systems and many other applications requiring high quality standards.

Our 5 years warranty applies on all LEM transducers delivered from the 1st. of January 1996 and is valid in addition to the legal warranty.

The warranty granted on our Transducers is for a period of 5 years (60 months) from the date of their delivery.

During this period we shall replace or repair at our cost all defective parts (provided the defect is due to defective material or workmanship).

Further claims as well as claims for the compensation of damages, which do not occur on the delivered material itself, are not covered by this warranty.

All defects must be notified to us immediately and faulty material must be returned to the factory along with a description of the defect.

Warranty repairs and or replacements are carried out at our discretion. The customer bears the transport costs. An extension of the warranty period following repairs undertaken under warranty cannot be granted.

The warranty will be invalidated if the buyer has modified or repaired, or has had repaired by a third party the material without LEM's written consent.

The warranty does not cover any damage caused by incorrect conditions of use and cases of force majeure. No responsibility will apply except legal requirements regarding product liability.

The warranty explicitly excludes all claims exceeding the above conditions.

LEM, Geneva, January 1. 2001
Business Area Components

A handwritten signature in black ink, appearing to read "P. Van Iseghem".

Paul Van Iseghem
President of LEM Components

LEM International Sales Representatives

Europe • Middle East

Austria
LEM NORMA GmbH
Liebermannstrasse F01
A-2345 Brunn am Gebirge
Tel. +43 2236 69 15 01
Fax +43 2236 69 14 00
e-mail: ina@lem.com

BeNeLux
LEM Belgium sprl-bvba
Route de Petit-Roexulx, 95
B-7090 Braine-le-Comte
Tel. : +32 67 55 01 14
Fax : +32 67 55 01 15
e-mail : lbe@lem.com

Croatia
Proteus Electric
Via di Noghere 94/1
I-34147 Muggia-Aquilina
Tel. +39 040 23 21 88
Fax +39 040 23 24 40
e-mail:
dino.fabiani@proteuselectric.it

Czech Republic
PE & ED Spol. S.R.O.
Koblovska 101/23
CZ-71100 Ostrava/Koblov
Tel. +420 59 6239256
Fax +420 59 6239531
e-mail: peedova@peed.cz

Denmark
Motron A/S
Torsovej 4
DK-8240 Risskov
Tel. +45 87 36 86 00
Fax +45 87 36 86 01
e-mail: motron@motron.dk

Finland
Etra-Dielectric Oy
Lampputie 2
SF-00741 Helsinki
Tel. +358 207 65 160
Fax +358 207 65 23 11
e-mail: markku.soitila@etra.fi

Field Applications Engineer
Dominique Roggo
Tel. +358 40 564 22 91
e-mail: dro@lem.com

France
LEM France Sarl
La Ferme de Courtaboeuf
19 avenue des Indes
F-91969 Courtaboeuf Cedex
Tel. +33 1 69 18 17 50
Fax +33 1 69 28 24 29
e-mail: lfr@lem.com

Germany
Central Office:
LEM Deutschland GmbH
Frankfurter Strasse 74
D-64521 Gross-Gerau
Tel. +49 61 52 9301 0
Fax +49 61 52 8 46 61
e-mail: postoffice.ide@lem.com

Hauber & Graf Electronics GmbH
Bavaria / Baden Württemberg
Wahlwiesenstr. 3
D-71711 Steinheim
Tel: +49 7144 28 15 03/04
Fax: +49 7144 28 15 05
e-mail: electronics@hauber-graf.de

Hungary
Orszaczky Trading LTD.
Korányi Sandor U, 28
H-1089 Budapest
Tel. +36 1 314 4225
Fax +36 1 324 8757
e-mail: orszaczky@axelero.hu

Italy
LEM Italia Srl
via V. Bellini, 7
I-35030 Selvazzano Dentro, PD
Tel. +39 049 805 60 60
Fax +39 049 805 60 59
e-mail: lit@lem.com

Israel
Ofer Levin Technological Application
PO Box 18247
IL- Tel Aviv 611 81
Tel. +972 3 5586279
Fax +972 3 5586282
e-mail: ol_teap@netvision.net.il

Norway
Holst & Fleischer A/S
Stansveien 6B
N-0975 Oslo
Tel. +47 2333 8500
Fax +47 2333 8501
e-mail: knut@hf-elektron.no

Poland
DACPOL Sp. z o.o.
Ul. Pulawska 34
PL-05-500 Piaseczno K. Warszawa
Tel. +48 22 7500868
Fax +48 22 7035101
e-mail: dacpol@dacpol.com.pl

Portugal
QEnergy, Lda
Praceta Cesário Verde - 10 S/Cave
P-2745-740 Massamá
Tel. +351 214 309320
Fax +351 214 309299
e-mail: qenergia@qenergia.pt

Romania
SYSOCOM - 18 Srl.
Rotopopescu 10, bl. 4. ap 2 Sector 1
R-011728 Bucharest
Tel. +40 21 310 26 78
Fax +40 21 310 26 79
e-mail: georgeb@syscom.ro

Russia
Central Office:
TVELEM
Marshall Budionny Str. 11
170023 Tver / Russia
Tel. +7 822 44 40 53
Fax +7 822 44 40 53
e-mail: tvelem@lem.com

TVELEM
Leningradski Avenue, d. 80
Korp. 32, 3d floor, room 19.
125190 Moscow
Tel. +7 095 363 07 67
Fax +7 095 363 07 67
e-mail: tvelem@lem.com

TVELEM
V.O., 2 linia, 19, Liter „A“
199053 S. Petersburg
Tel. +7 812 323 83 83
Fax +7 812 323 83 83
e-mail: tvelem@lem.com

Slovenia
Proteus Electric
Via di Noghere 94/1
I-34147 Muggia-Aquilina
Tel. +39 040 23 21 88
Fax +39 040 23 24 40
e-mail: dino.fabiani@proteuselectric.it

Spain
LEM Components
Stefan Lüscher
Tel. +34 93 886 02 28
Fax +34 93 886 60 87
e-mail: sltu@lem.com

AVANZEL
COMPONENTES, S.L.
Madrid region
Avda. Sancho Rosa 66
E-28708 San Sebastián de los Reyes
Tel. +34 91 6236828
Fax +34 91 6236702
e-mail: ventas@avanzel.com

Sweden
Beving Elektronik A.B.
Jägerhorns väg 8
S-14105 Huddinge
Tel. +46 8 6801199
Fax +46 8 6801188
e-mail:
information@bevingelektronik.se

Switzerland
SIMPEX Electronic AG
Binzackerstrasse 33
CH-8622 Wetzikon
Tel. +41 1 931 10 10
Fax +41 1 931 10 11
e-mail: contact@simpex.ch

LEM SA
8, Chemin des Aulx
CH-1228 Plan-les-Ouates
Tel. +41 22 706 11 11
Fax +41 22 794 94 78
e-mail: lsa@lem.com

Turkey
Özdisan Elektronik Pazarlama
Galata Kulesi Sokak N° 34
TR-80020 Kuledibi / Istanbul
Tel. +90 212 2499806
Fax +90 212 2436946
e-mail: oabdi@ozdisan.com

United Kingdom and Eire
LEM UK Sales
Geneva Court, 1
Penketh Place, West Pimbo
Skelmersdale
Lancashire WN8 9QX
Tel. +44 1 695 57 07 77
Fax +44 1 695 57 07 04
e-mail: luk@lem.com

Africa, America

Brazil
Intech Engenharia Ltd
5 Andar CJ 52
Av. Adolfo Pinheiro 1010
BR-04734-002 Sao Paulo
Tel. +55 11 5548 1433
Fax +55 11 5548 1433
e-mail: intech@intech-engenharia.com.br

Canada
Optimum Components Inc.
7750 Birchmount Road Unit 5
CAN-Markham ON L3R 0B4
Tel. +1 905 477 9393
Fax +1 905 477 6197
e-mail:
mikep@optimumcomponents.com

Chile
ELECTROCHILE
Freire 979 of. 303-304
Quilpue
Tel. +56 32 92 32 22
Fax +56 32 92 32 22
e-mail: elecchile@entchile.net

South Africa
Denver Technical Products Ltd.
P.O. Box 75810
SA-2047 Garden View
Tel. +27 11 626 20 23
Fax +27 11 626 20 09
e-mail: denvertch@pixie.co.za

U.S.A.
Central Office:
LEM U.S.A., Inc.
6643 West Mill Road
USA Milwaukee, WI 53218
Tel. +1 414 353 07 11
Toll free: 800 236 53 66
Fax +1 414 353 07 33
e-mail: lus@lem.com

LEM U.S.A., Inc.
999, Pennsylvania Ave.
USA-Columbus, OH 43201
Tel. +1 614 298 84 34
Fax +1 614 540 74 36
Mobile +1 614 306 73 02
e-mail: afg@lem.com

LEM U.S.A., Inc.
27 Rt 191A
PO Box 1207
USA-Amherst, NH 03031
Tel. +1 603 672 71 57
Fax. +1 603 672 71 59
e-mail: gap@lem.com

LEM U.S.A., Inc.
7885 Vance Drive
USA Arvada, CO 80003
Tel. +1 303 403 17 69
Fax. +1 303 403 15 89
e-mail: dlw@lem.com

Asia • Pacific

Australia and New Zealand
Fastron Technologies Pty Ltd.
25 Kingsley Close
Rowville - Melbourne -
Victoria 3178
Tel. +61 39 763 51 55
Fax +61 39 763 51 66
e-mail: sales@fastron.com.au

India
Globetek
122/49, 27th Cross
7th Block, Jayanagar
IN-Bangalore-560082
Tel. +91 80 2 663 57 76
Fax +91 80 2 653 40 20
e-mail: globetek@vsnl.com

Korea
Youngwoo Ind. Co.
C.P.O. Box 10265
K-Seoul
Tel. +82 2 312 66 88 58
Fax +82 2 312 66 88 57
e-mail: c.k.park@ygwoo.co.kr

Malaysia
Acei Systems SDN BHD
No. 3, SB Jaya 7
Taman Industri SB Jaya
47000 Sungai Buloh
Selangor, Malaysia
Tel. +60 36157 85 08/55 08
Fax +60 36157 15 18
e-mail: ssshullar@aceisys.com.my

Singapore
Overseas Trade Center Ltd.
03 - 168 Bukit Merah L. 1
BLK 125/Alexandra Vil
RS-150125 Singapore
Tel. +65 6 272 60 77
Fax +65 6 278 21 34
e-mail: octpl@signet.com.sg

POWERTRONICS CO. LTD
2F, No 138, Sec. 3
Chung-shin Rd. Shing-Tien,
Taipei-Hsien 231,
Taiwan, R.O.C.
Tel. +886 2 2915 7000
Fax +886 2 2915 3910
e-mail: powertr@ms22.hinet.net

China
Beijing LEM Electronics Co.
Ltd.
No. 1 Standard Factory
Building B
Airport Industria Area
CN-Beijing 101300
Tel. +86 10 80 49 04 70
Fax +86 10 80 49 04 73
e-mail: hzh@lem.com

Japan
NANALEM K.K.
2-1-2 Nakamachi
J-194-0021 Tokyo
Tel. +81 42 725 8151
Fax +81 42 728 8119
e-mail: nle@lem.com

Taiwan
Tope Co., Ltd.
P.O. Box 101-356
3F, No. 344, Fu Shing Road
ROC-10483 Taipei
Tel. +886 2 509 54 80
Fax +886 2 504 31 61
e-mail: tope@ms1.hinet.net

BAC/E, 11.04



LEM Components
8, Chemin des Aulx, CH-1228 Plan-les-Ouates
Tel. +41/22/706 11 11, Fax +41/22/794 94 78
e-mail: lsa@lem.com; www.lem.com

Publication CH 24108 E/US (11.04 • 9/6 • CDH)

Distributor